

INSTALLATION INSTRUCTIONS Marmoxan™ Solid Surface Wall

Date of issue: 04.12.2024

Please read all instructions before installing products.

STORAGE:

Marmoxan™ wall cladding must be stored flat and fully supported with no sagging or bowing. The pallets that Marmoxan™ wall cladding is shipped on are ideal for storing the wall cladding as long as they remain in good condition and can maintain a flat level surface. It is imperative that the panels remain as flat as possible in order to avoid damage. Marmoxan™ must be stored in a dry and well-ventilated area between 15°-25°C.

BEFORE INSTALLATION:

Check for damage that may have occurred in transit. Store materials in an environmentally controlled area, 24 hours before installation. Confirm that the sizes, styles/models, and colors match your order. Check all specifications to ensure that you have the right material for the job. To ensure that seams line up and are as inconspicuous as possible, ensure that the substrate and sub-wall are flat, plumb, and square.

When installing wall cladding ensure back of panel is no more than 1/16" from wall substrate.

RECOMMENDED TOOLS:

Belt sander, jig saw, circular saw with fine tooth carbide blades, router (1-3/4" HP, 22,000 rpm), random orbital sander, electric drill with carbide or high speed steel bits, tape measure, grease pencil, clamps, denatured alcohol, safety goggles, white paper towels, caulking gun, dust masks, masking tape, level/straight edge,

If needed: 3" clear packaging tape, scotch brite pads, 250ml hard seam adhesive dispenser, extra hard seam mixing tips

USING TOOLS:

Sawing:

Cut only on finished side (front) and use wide masking tape to protect finished surfaces from scratching or chipping.

Drilling:

Drill from finished side (front) of material.

Sanding:

Always saw, drill, or sand with the material fully supported. See Figure 1. on the following page. The shipping pallet is an ideal work surface.

ADHESIVES AND SEALANTS:

Translucent 100% Silicone

Color Matched Silicone (if specified)

. Color Matched Hard Seam Adhesive (if specified)

PRIMING:

Certain colors may have translucent or semi-transparent properties which will require the substrate to be primed with latex primer to prevent dark areas from showing through the sheet.

INSTALLATION INSTRUCTIONS Marmoxan™ Solid Surface Wall

Date of issue: 04.12.2024

Please read all instructions before installing products.

FIG. 1

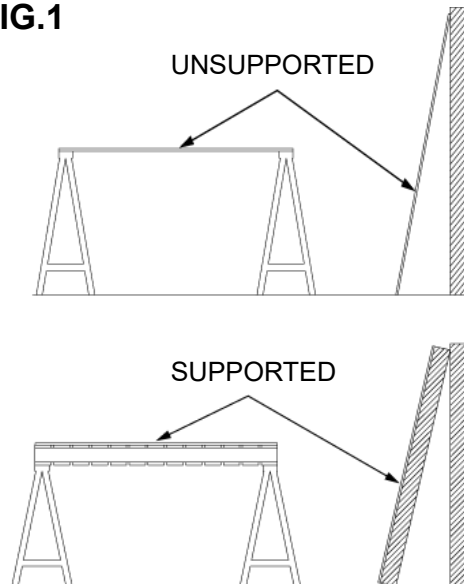

FIG. 2

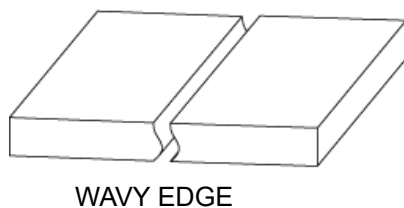

FIG. 3

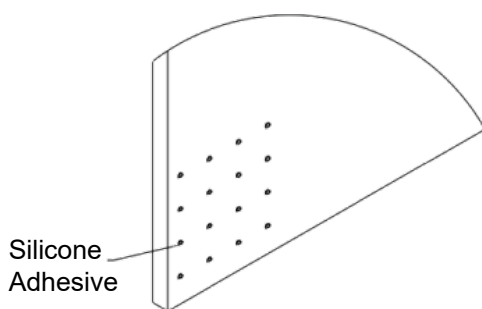
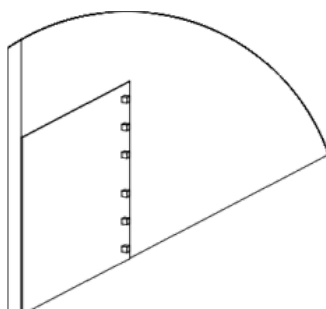

FIG. 4



1. In advance determine where hard seams, soft seams, batten strips, corner moldings, and perimeter trim will occur. (Soft seams must occur at inside corners) Cut material to the required size.

Hard Seaming: Hard seaming is the joining of two or more panels with two-part color matched hard seam adhesives to form inconspicuous seams.

Soft Seaming: Soft seaming is the joining of two or more panels with color matched or translucent silicone to form subtle seams.

2. Clean and prime wall substrate if needed before installing Marmoxan™ wall panels. Dark or uneven colors on the wall substrate may cause ghosting of the substrate through the wall panels.
3. Dry fit panels to ensure proper fit.

Note:

- Fully support wall panels while carrying or cutting to avoid damaging the panels. See Figure 1.
 - It is recommended to use a circular saw with a fine-tooth carbide blade to cut panels to size.
 - For panels that are being seamed together, inspect for color variation and choose panels that have the least color variation to achieve a consistent look.
4. Clean the wall panels, including the edges that will be bonded, with denatured alcohol and a clean white paper towel.

Hard Seaming: (If install doesn't call for "Hard Seams" proceed to Step 15.)

Note:

- Hard seams may be created on a flat work surface, apply packaging tape under the seam on the work surface to ensure that the adhesive doesn't stick to the work surface
 - Cut edges straight and. See Figure 2.
5. Apply quarter coin-sized drops of silicone adhesive to the wall where the first panel will be installed. Space the silicone 4" from each edge and every 8" to 10" over the rest of the field. See Figure 3.
 6. Position the first panel on the wall and press it into place. Hot melt glue may be used to hold the panel in place on uneven surfaces while the silicone cures.
 7. Apply clamping blocks made of wood to the surface of each wall panel with clear hot melt glue. Blocks should be 3" from each edge and at least every 6" over the length of the seam. See Figure 4.

INSTALLATION INSTRUCTIONS Marmoxan™ Solid Surface Wall

Date of issue: 04.12.2024

Please read all instructions before installing products.

FIG. 5

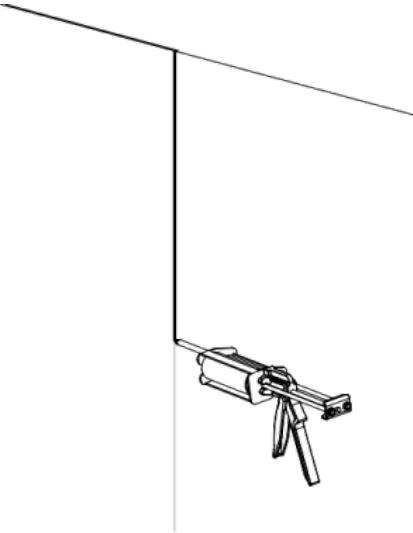

8. Apply quarter coin-sized drops of silicone adhesive to the wall where the second panel will be installed.
9. Position the second panel on the wall and press it into place, leave an 1/8" gap in between the panels.

Note:

- Before applying hard seam adhesive, purge a small amount of adhesive through the tip to ensure that the adhesive is properly mixed.

10. Apply two-part color matched hard seam adhesive in a uniform bead to the entire seam. See Figure 5.

11. Clamp the seam together across the wood blocks until some of the adhesive squeezes out to form a uniform bead along the entire seam. See Figure 6.

Note:

- Do not tighten the clamps too tight, this can starve the seam of adhesive. You want a minimum of 1/32" to 1/16" of adhesive between the panels.
- Vacuum Clamps may also be used in place of the wood blocks and clamps.

FIG. 6

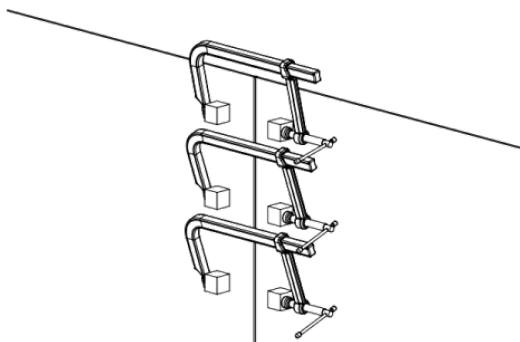

12. Allow the adhesive to cure (30-60min).

13. Remove the clamps and clamping blocks.

14. Using a random orbital sander, sand off the excess adhesive and blend it into the existing panel finish. See Figures 7 & 8 for panel finishing details.

FIG. 7

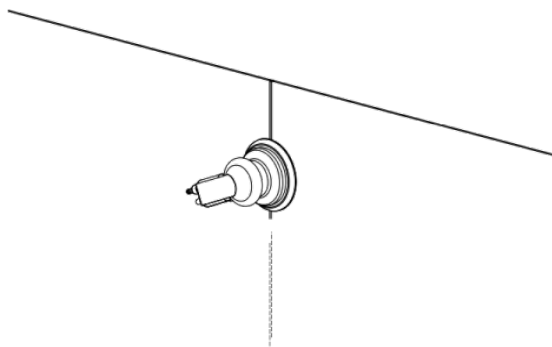

Note:

- Move the sander in an orbital pattern and overlap 50% per pass. Keep the sander moving so you don't over heat the seam, over heating the joint can weaken or wreck the bond.

Marmoxan™ - Satin Finish:

- Use a 100 micron sanding pad to remove excess material and even out the surface.
- Repeat the process with a 60 micron sanding pad.
- Use a Scotch-Brite® pad (#7447 Maroon, Very Fine, 320-400 Grit) under the sanding pad to even out the finish.
- Repeat the process with a Scotch-Brite® pad (#7448 Gray, Ultra Fine, 600-800 Grit).

INSTALLATION INSTRUCTIONS Marmoxan™ Solid Surface Wall

Date of issue: 04.12.2024

Please read all instructions before installing products.

FIG.9

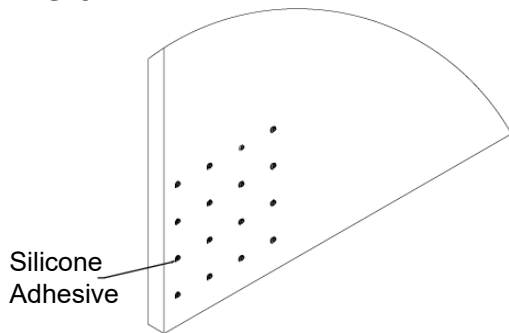

FIG. 10

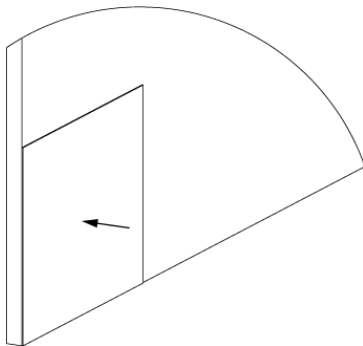

FIG. 11

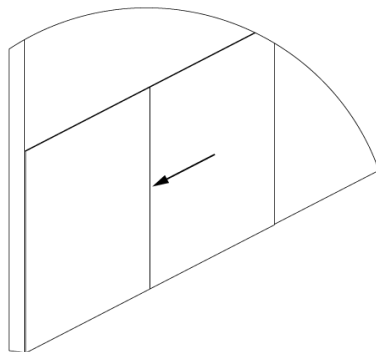
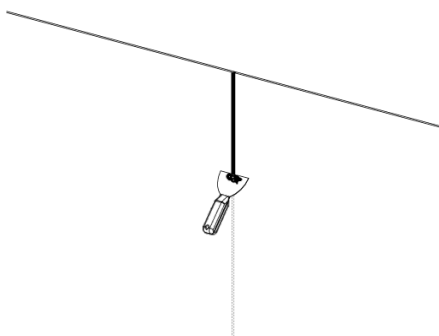

FIG. 12



Soft Seaming:

15. Apply quarter coin-sized drops of silicone adhesive to the wall where the first panel will be installed. Space the silicone 4" from each edge and every 8" to 10" over the rest of the field. See Figure 9.
16. Position the first panel on the wall and press it into place. Hot melt glue may be used to hold the panel in place on uneven surfaces while the silicone cures. See Figure 10.
17. Apply quarter coin-sized drops of silicone adhesive to the wall where the second panel will be installed.
18. Apply a bead of silicone to the edge of the first panel where the panels will meet.
19. Position the second panel on the wall and press it into place, leave an 1/8" gap in between the panels.
20. Slide the panels together to form a uniform seam. There should be a minimum of 1/16" gap between the panels. See Figure 11.
21. Apply silicone to the joint to make sure the entire seam is full.
22. Using denatured alcohol and a flat edged tool such as a putty knife, clean excess silicone from the face of the joint.

Note:

- Spray the denatured alcohol over the silicone and wall panels around the joint before you scrape the excess silicone off. This prevents silicone from sticking to the wall panels. Do not wipe excess silicone off with a rag, this will leave a dull uneven finish that will not blend in.

INSTALLATION INSTRUCTIONS Marmoxan™ Solid Surface Wall

Date of issue: 04.12.2024

Please read all instructions before installing products.

23. After all panels are adhered to the wall, mask off the edges of any gaps. Fill in all gaps between panels, wall base and corner conditions with translucent or color matched silicone. Smooth out silicone and remove the masking tape. Clean-up any excess silicone with denatured alcohol. See Figure 13.

FIG. 13

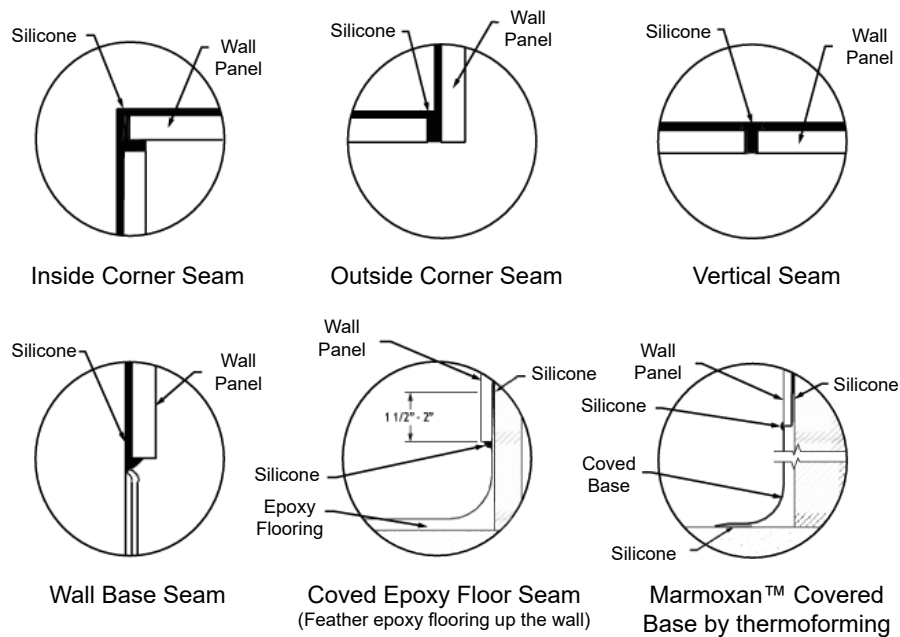

24. Trim: (Figure 14)

- Cut the trim to the required length.
- Apply silicone adhesive to the wall where the trim will be installed.
- Firmly press the trim into place.
- If needed/desired, apply a bead of silicone around the perimeter of where the trim meets the wall.
- Remove excess silicone adhesive with denatured alcohol.
- Use masking tape to hold the trim in place until the silicone cures.
- Allow silicone to completely cure before use.

FIG. 14

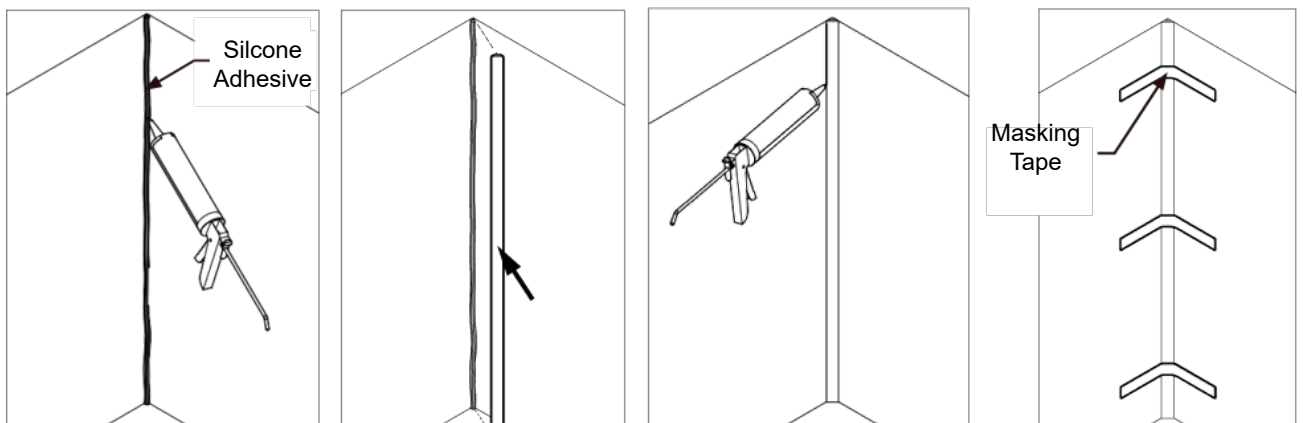

INSTALLATION INSTRUCTIONS Marmoxan™ Solid Surface Wall

Date of issue: 04.12.2024

Please read all instructions before installing products.

FIG. 15

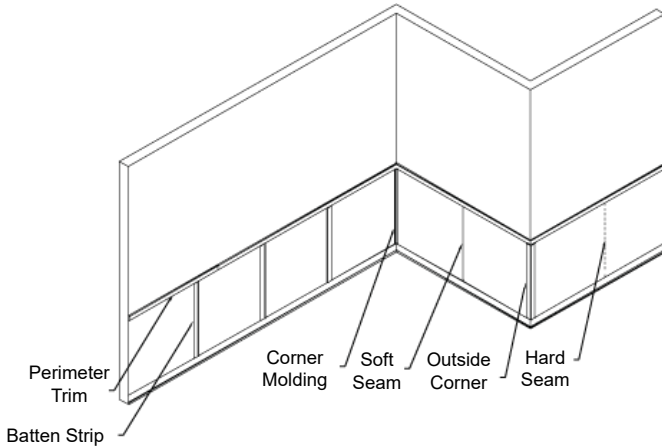

FIG. 16A



FIG. 16B



FIG. 16C

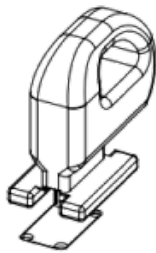
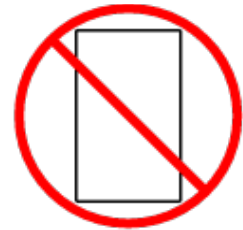

FIG. 16D



FIG. 16C



25. Making Cutouts: (Figures 16A-16E)

- Mark the desired hole location.
- Drill 1/2" diameter pilot holes in each corner of the cutout location.
- Cut in-between each pilot hole to create the desired shape.
- Apply a thin bead of silicone adhesive to the wall 2" from the cutout location.

Note:

- The radius from the pilot holes will help prevent cracking in the corners.
- A jig saw, router, or dremel tool will work well to make the cutouts.

26. Outside Corner Hard Seam: (Figures 17A-17E)

- Adhere the first panel to the wall, flush with the edge of the corner.
- Adhere the second panel to the wall, it will over hang the corner by an inch or two
- Apply wood blocks to the surface of the first panel with hot melt glue, 3" from the edge and every 6" over the length of the seam.
- Apply wood blocks to the inside corner, where each panel meets the adjacent wall (if applicable).
- Fill the gap between the panels with color matched hard seam.
- Apply clamps from the wood blocks on the first sheet to the outside of the second sheet.
- Let the hard seam cure.
- Remove all wood blocks.
- Trim over hanging panel material with a router.
- Finish the seam and corner to match the wall panel finish.

Note:

- A radiused router bit and finish router may be used to add a radius to the corner.

INSTALLATION INSTRUCTIONS Marmoxan™ Solid Surface Wall

Date of issue: 04.12.2024

Please read all instructions before installing products.

FIG. 17A

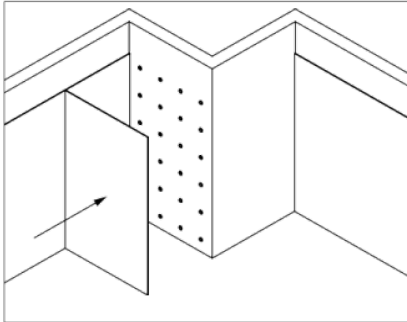

FIG. 17B

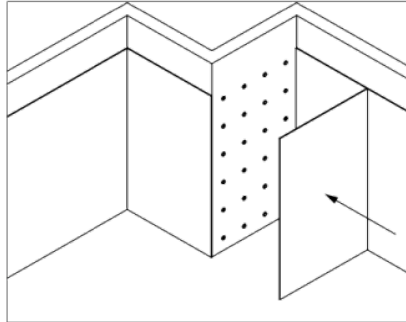

FIG. 17C

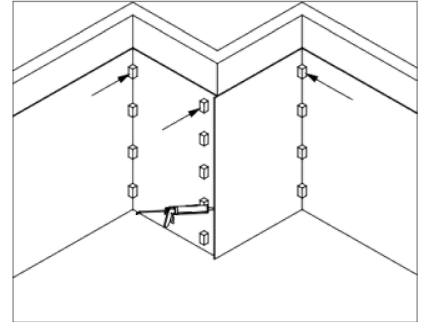

FIG. 17D

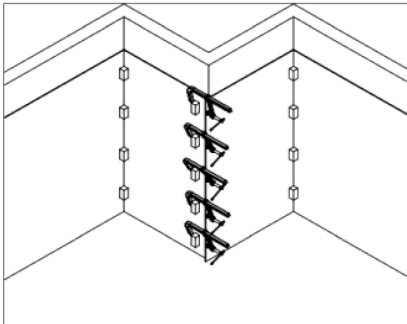
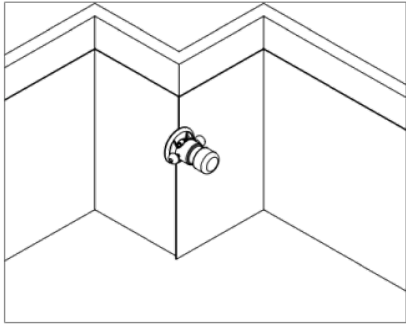

FIG. 17E



27. Mounting on Top of Wall Cladding: (Figures 18A-18C)

- Prepare to install the wall cladding per the wall cladding installation steps.
- Add coils of silicone to the wall where any fixtures will be mounted. These coils are to cover an area larger than the fixture and be approximately 1/4" thick.
- Install the wall cladding, allowing the silicone to cure for at least 24hrs.
- Install the fixture per the manufacturer's install instructions, hand tightening the fasteners only.

Note: Drill clearance holes slightly larger than the fastener, a 1/4" deep, to prevent damage to the wall cladding.

Caution: Hand tighten mounting screws to avoid damaging wall cladding. DO NOT TIGHTEN WITH POWER TOOLS.

FIG. 18A

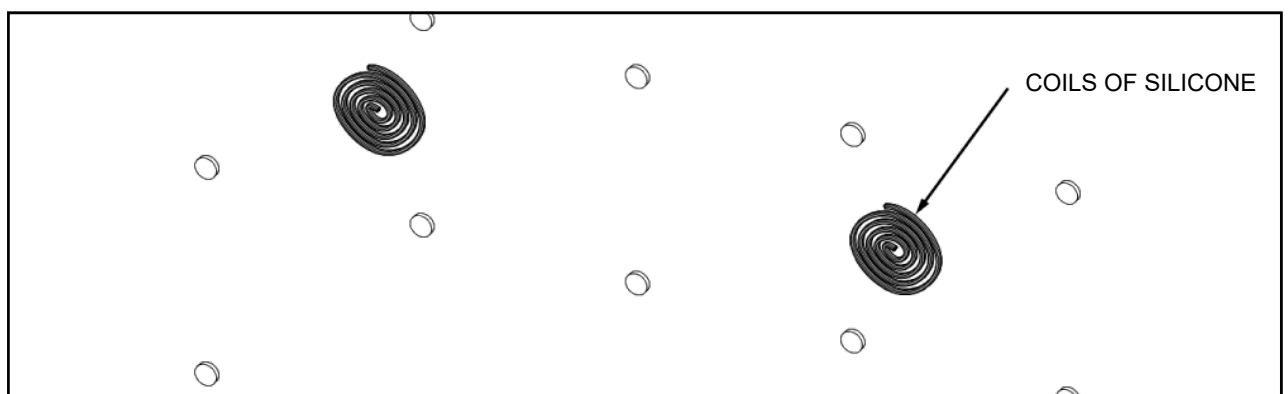

INSTALLATION INSTRUCTIONS Marmoxan™ Solid Surface Wall

Date of issue: 04.12.2024

Please read all instructions before installing products.

FIG. 18B

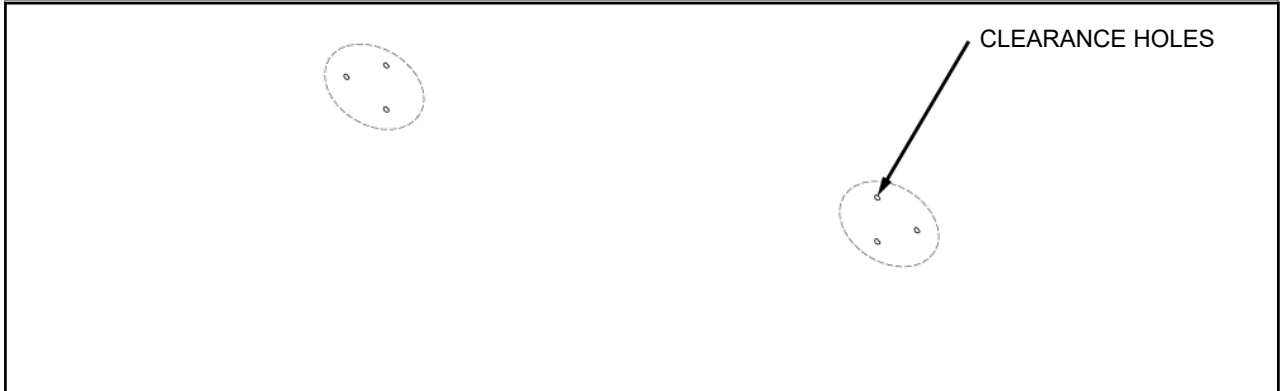
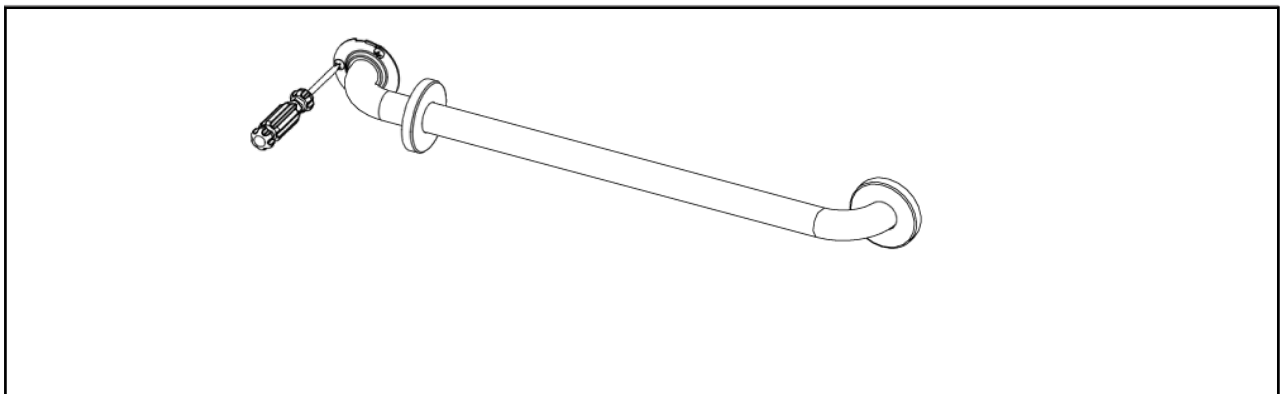

FIG. 18C



HARD SEAMED WALL LENGTH LIMITATIONS:

- When designing long spans of Marmoxan™ Solid Surface wall cladding, you must take into consideration the temperatures at which the Marmoxan™ will be installed and the expected deviation from the installation temperature. The deviation limits the length of install you can make without soft seams. The chart below shows the hard-seamed wall length limits as a function of expected temperature change (ΔT).

ΔT (°F)	Max Length (ft.)
±10	60
±15	40
±20	30
±25	24
±30	20
±35	17
±40	15

- 24 hours before the installation, acclimate the Marmoxan™ Solid Surface wall cladding and silicone adhesive to the environmentally controlled area where it will be installed. Maintain a constant temperature & humidity level in the installation area, 24 hours before installation, during the entire installation, and after the installation. Large temperature changes can cause damage to wall cladding and seams.
- Marmoxan™ Solid Surface wall cladding is to be installed with 100% silicone adhesive with 50% movement capability.

INSTALLATION INSTRUCTIONS Marmoxan™ Solid Surface Wall

Date of issue: 04.12.2024

Please read all instructions before installing products.

- Soft seams are to be 1/8" wide and filled with 100% silicone adhesive.
- For wall to wall installations, install the back-wall panel first leaving 1/8" gaps in each corner. These gaps are to be filled with 100% silicone adhesive. These silicone joints allow for the wall cladding to expand and contract as temperatures change. When installing the side wall cladding, the wall cladding will hide the soft seam joint in the corners.
- When making cutouts in the wall cladding ensure that the openings in the Marmoxan™ are slightly oversized to allow for the panels to expand and contract as the temperature changes without contacting the fixtures or boxes.
- When mounting on top of Marmoxan™ ensure that you drill oversized clearance holes through the Marmoxan™ where fasteners are needed. This will allow for the panels to expand and contract as the temperature changes.

